

Revisions

Issue	Date	Note
1	08/4/2022	See GTXPDC/472

DATASHEET

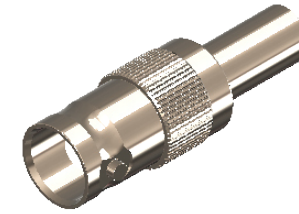

1. Mechanical

Cable Retention	Equal to breaking strain of cable
Durability	500 mating cycles
Fixing Method	Crimp

2. Environmental

RoHS Compliant	Yes
Temperature Range	-55 to +85 degrees C

3. Electrical

Dielectric Withstanding	1500 Volts RMS Maximum
Impedance	50 ohms
Interface Frequency	4 GHz
Working Voltage	500 Volts RMS Maximum

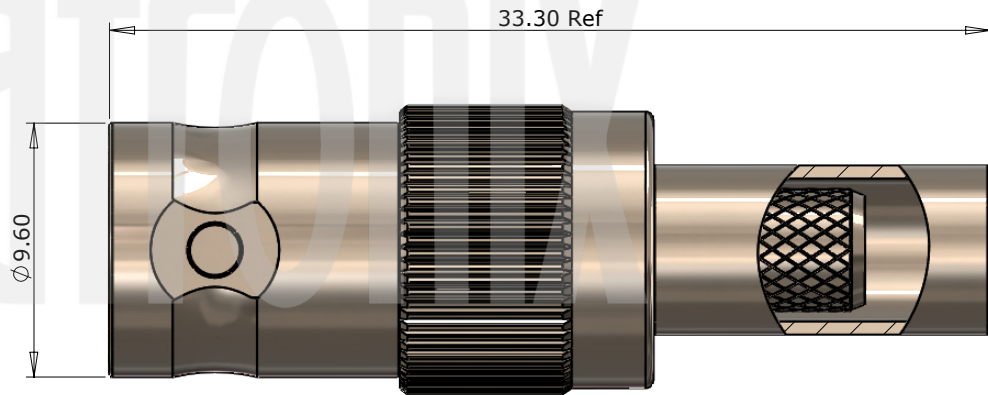

Description	Material	Finish
4 Ferrule	Brass	Nickel
3 Dielectric	Delrin	White
2 Contact	Brass	Gold
1 Body	Zinc Alloy	Nickel

Unless otherwise specified tolerances
 0.5-5 = ±0.2
 >5-30 = ±0.4
 >30-120 = ±0.6
 >120-315 = ±1.0
 >315-1000 = ±1.6
 Angles = ±5°
 Units = mm

This document is the confidential property of Gigatronix Limited and may not be copied, reproduced or transmitted to any third party without written authorisation.



Author	PJP
Drawn by	PJP
Drawing date	08/4/2022
Checked by	DB
Checked date	13/04/2022
Scale	Not to scale

Part Number BN10-0058-C06D

Title: BNC Crimp Jack, Nickel Plated, RG58, LBC195, URM43

Revisions

Issue	Date	Note
1	08/4/2022	See GTXPDC/472

ASSEMBLY INSTRUCTIONS

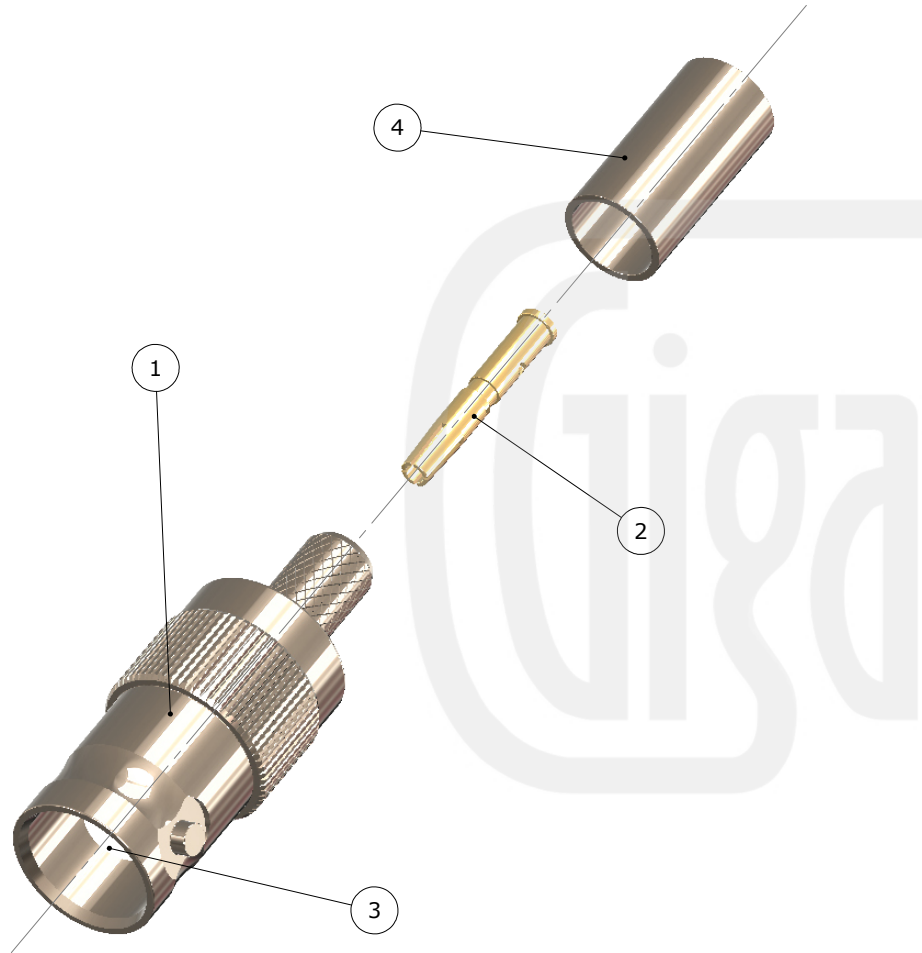

Assembly Instructions:

1) Slide the ferrule onto the cable and strip the cable to the dimensions as shown, taking care not to nick the centre conductor or braid



2) Crimp the contact onto the centre core and slide the contact into the body until it captivates, ensuring that the cable braid is on the outside of the connector mandril

3) Slide the ferrule forward and crimp

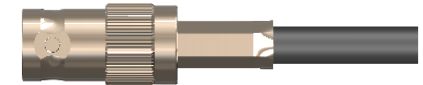

Crimp Hex. Sizes:
5.41mm Hex., 1.69mm Hex

Strip Dimensions:
A=8.0mm, B=4.0mm, C=4.0mm



Description	Material	Finish
4 Ferrule	Brass	Nickel
3 Dielectric	Delrin	White
2 Contact	Brass	Gold
1 Body	Zinc Alloy	Nickel

Unless otherwise specified tolerances
 0.5-5 = ±0.2
 >5-30 = ±0.4
 >30-120 = ±0.6
 >120-315 = ±1.0
 >315-1000 = ±1.6
 Angles = ±5°
 Units = mm

This document is the confidential property of Gigatronix Limited and may not be copied, reproduced or transmitted to any third party without written authorisation.



Author	PJP
Drawn by	PJP
Drawing date	08/4/2022
Checked by	DB
Checked date	13/04/2022
Scale	Not to scale

Part Number BN10-0058-C06D

Title: BNC Crimp Jack, Nickel Plated, RG58, LBC195, URM43