

Revisions

Issue	Date	Note
2	16/12/2022	See note GTXPDC/627 - checked DB 16/12/2022

DATASHEET

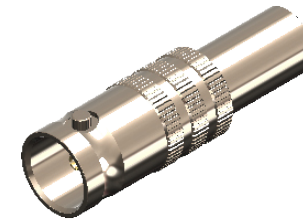

1. Mechanical

Cable Retention	Equal to breaking strain of cable
Fixing Method	Crimp
Durability	500 mating cycles
Contact Termination	Crimp

2. Environmental

RoHS Compliant	Yes
Temperature Range	-65 to +165 degrees C

3. Electrical

Dielectric Withstanding	1500 Volts RMS Maximum
Impedance	75 ohms
Interface Frequency	12 GHz
Working Voltage	500 Volts RMS Maximum

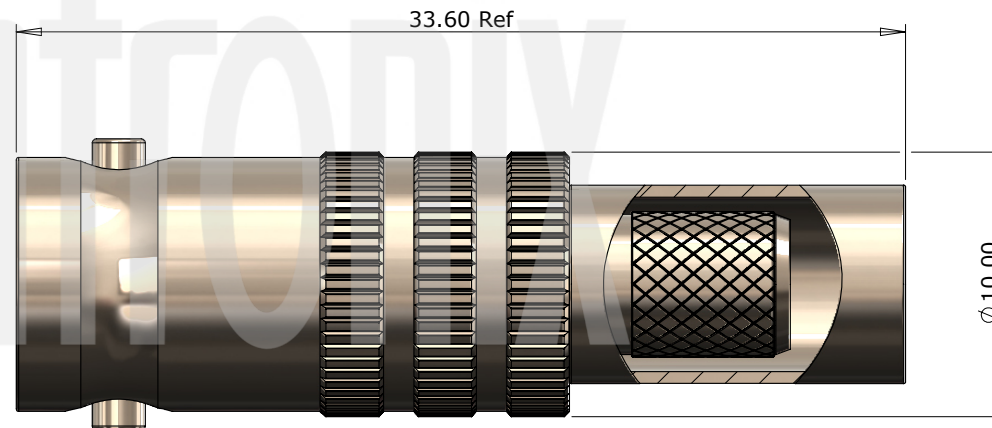

Description	Material	Finish
5 Insulator	PTFE	White
4 Ferrule	Brass	Nickel
3 Dielectric	PTFE	White
2 Contact	Phosphor Bronze	Gold
1 Body	Brass	Nickel

Unless otherwise specified tolerances
 0.5-5 = ±0.2
 >5-30 = ±0.4
 >30-120 = ±0.6
 >120-315 = ±1.0
 >315-1000 = ±1.6
 Angles = ±5°
 Units = mm

This document is the confidential property of Gigatronix Limited and may not be copied, reproduced or transmitted to any third party without written authorisation.



Author	PJP
Drawn by	PJP
Drawing date	21/08/2020
Checked by	DB
Checked date	21/08/2020
Scale	Not to scale

Part Number	BN10-1505-C06-Z
Title:	BNC 12G SDI Crimp Jack, Nickel Plated, Belden 1505A, 4505R

Revisions		
Issue	Date	Note
2	16/12/2022	See note GTXPDC/627 - checked DB 16/12/2022

ASSEMBLY INSTRUCTIONS

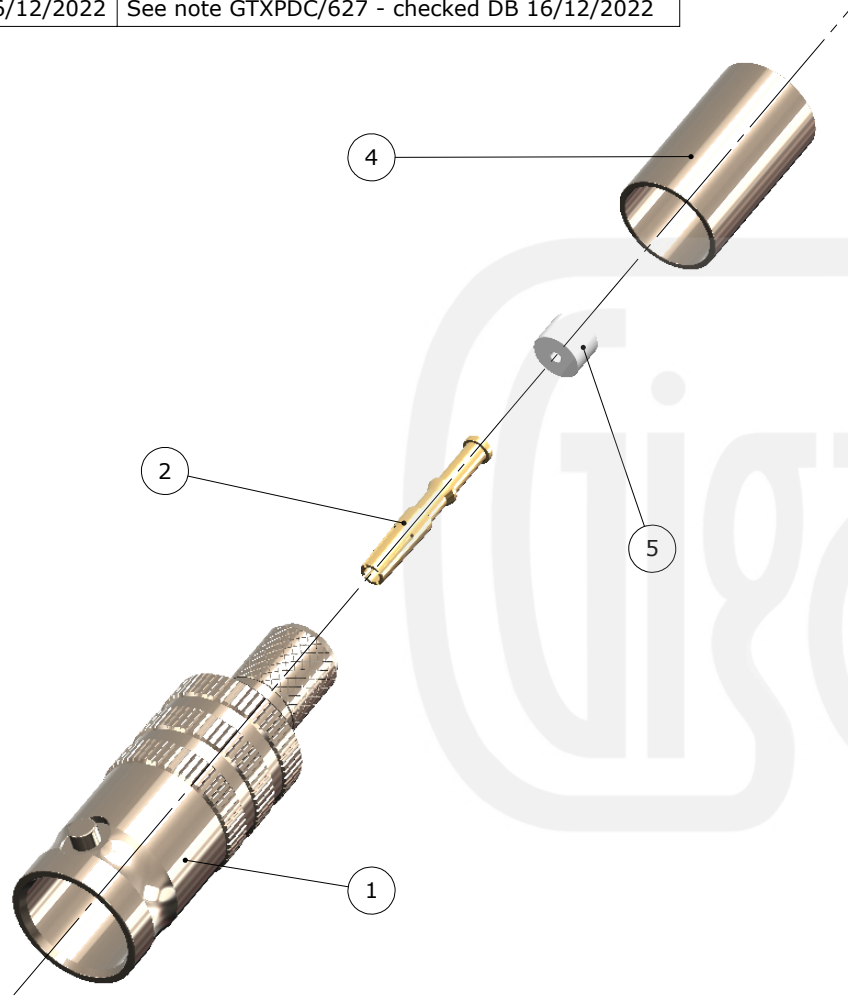

Assembly Instructions:

1) Slide the ferrule onto the cable and strip the cable to the dimensions as shown, taking care not to nick the centre conductor or braid

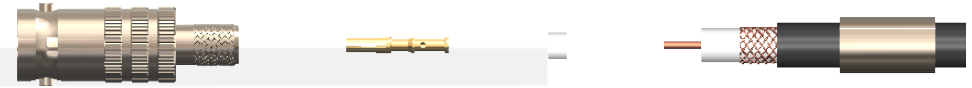

2) Slide the insulator over the centre core. Crimp the contact onto the centre core and slide the contact into the body until it captivates, ensuring that the cable braid is on the outside of the connector mandril

3) Slide the ferrule forward and crimp



Crimp Die Sizes:
6.48mm Hex., 1.07mm Square

Strip Dimensions:
A=8.5mm, B=2.1mm, C=6.0mm



Description	Material	Finish
5 Insulator	PTFE	White
4 Ferrule	Brass	Nickel
3 Dielectric	PTFE	White
2 Contact	Phosphor Bronze	Gold
1 Body	Brass	Nickel

Unless otherwise specified tolerances
 0.5-5 = ±0.2
 >5-30 = ±0.4
 >30-120 = ±0.6
 >120-315 = ±1.0
 >315-1000 = ±1.6
 Angles = ±5°
 Units = mm

This document is the confidential property of Gigatronix Limited and may not be copied, reproduced or transmitted to any third party without written authorisation.



Author	PJP
Drawn by	PJP
Drawing date	21/08/2020
Checked by	DB
Checked date	21/08/2020
Scale	Not to scale

Part Number BN10-1505-C06-Z

Title: BNC 12G SDI Crimp Jack, Nickel Plated, Belden 1505A, 4505R