

Revisions

| Issue | Date | Note |
|-------|------------|-----------------|
| 4 | 26/11/2024 | See GTXPDC/1029 |



1. Mechanical

| | |
|-----------------|-----------------------------------|
| Cable Retention | Equal to breaking strain of cable |
| Durability | 500 mating cycles |
| Fixing Method | Crimp |

2. Environmental

| | |
|-------------------|-----------------------|
| RoHS Compliant | Yes |
| Temperature Range | -65 to +165 degrees C |

3. Electrical

| | |
|-------------------------|-----------------------|
| Dielectric Withstanding | 500 Volts RMS Maximum |
| Impedance | 75 ohms |
| Interface Frequency | 12 GHz |
| Working Voltage | 500 Volts RMS Maximum |

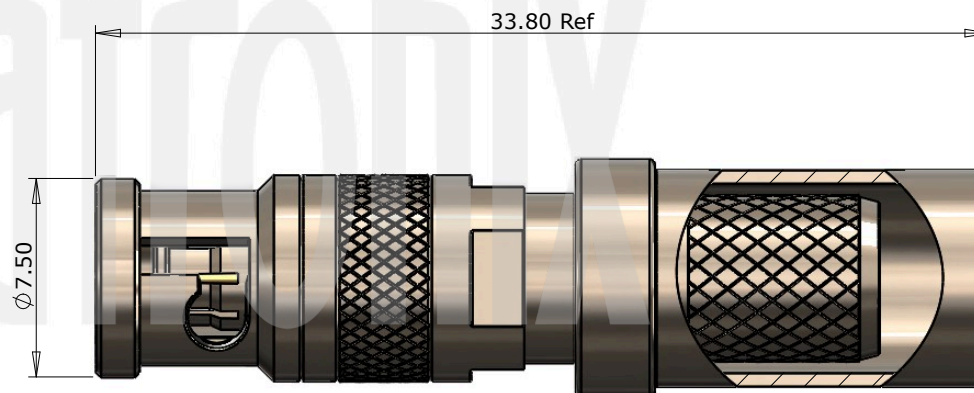

| | | | |
|---|--------------------|------------------|---------------|
| 5 | Dielectric | PTFE | White |
| 4 | Ferrule | Brass | Nickel |
| 3 | Coupling Nut | Brass | Nickel |
| 2 | Pin | Beryllium Copper | Gold |
| 1 | Body | Brass | Nickel |
| | Description | Material | Finish |

Unless otherwise specified tolerances
 0.5-5 = ±0.2
 >5-30 = ±0.4
 >30-120 = ±0.6
 >120-315 = ±1.0
 >315-1000 = ±1.6
 Angles = ±5°
 Units = mm

This document is the confidential property of Gigatronix Limited and may not be copied, reproduced or transmitted to any third party without written authorisation.



| | |
|---------------------|--------------|
| Author | PJP |
| Drawn by | PJP |
| Drawing date | 13/07/2016 |
| Checked by | DB |
| Checked date | 11/09/2018 |
| Scale | Not to scale |

| | |
|--|-----------------|
| Part Number | HD15-1694-C06-Z |
| Title: HD BNC 12G SDI Crimp Plug, Nickel Plated, Gigatronix UHD75-6 / 6XF, Belden 4694R | |

Revisions

| Issue | Date | Note |
|-------|------------|-----------------|
| 4 | 26/11/2024 | See GTXPDC/1029 |

ASSEMBLY INSTRUCTIONS



Assembly Instructions

1) Slide the ferrule onto the cable and strip the cable to the dimensions as shown, taking care not to nick the centre conductor or braid.



2) Crimp the pin onto the centre core and slide the pin into the body until it captivates, ensuring that the cable braid is on the outside of the connector mandril.

3) Slide the ferrule forward and crimp.

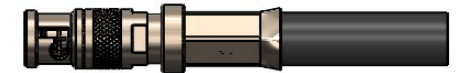

Crimp Die Sizes:
7.06mm Hex., 1.07mm sq. or Hex.

Strip Dimensions:
A=8.9mm, B=2.1mm, C=4.0mm



| Description | Material | Finish |
|----------------|------------------|--------|
| 5 Dielectric | PTFE | White |
| 4 Ferrule | Brass | Nickel |
| 3 Coupling Nut | Brass | Nickel |
| 2 Pin | Beryllium Copper | Gold |
| 1 Body | Brass | Nickel |

Unless otherwise specified tolerances
 0.5-5 = ±0.2
 >5-30 = ±0.4
 >30-120 = ±0.6
 >120-315 = ±1.0
 >315-1000 = ±1.6
 Angles = ±5°
 Units = mm

This document is the confidential property of Gigatronix Limited and may not be copied, reproduced or transmitted to any third party without written authorisation.



| | |
|--------------|--------------|
| Author | PJP |
| Drawn by | PJP |
| Drawing date | 13/07/2016 |
| Checked by | DB |
| Checked date | 11/09/2018 |
| Scale | Not to scale |

Part Number HD15-1694-C06-Z

Title: HD BNC 12G SDI Crimp Plug, Nickel Plated, Gigatronix UHD75-6 / 6XF, Belden 4694R