

Revisions

Issue	Date	Note
1	21/02/2017	See note 408784336

SUMMARY VIEW

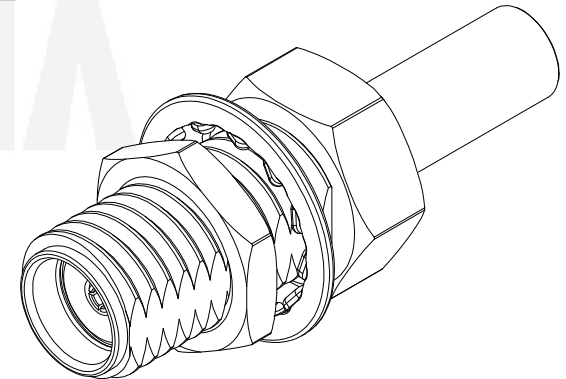
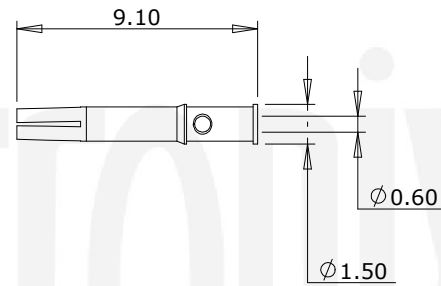
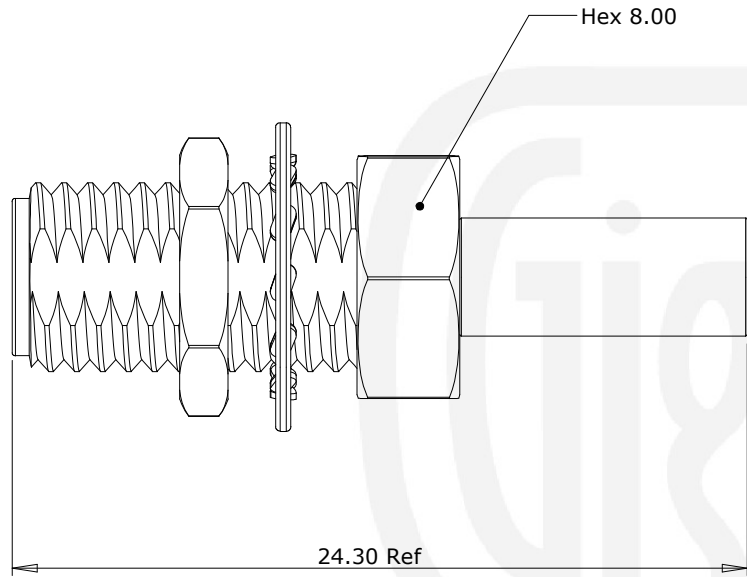

6	Dielectric	PTFE	White
5	Washer	Brass	Gold
4	Locknut	Brass	Gold
3	Ferrule	Brass	Gold
2	Contact	Phosphor Bronze	Gold
1	Body	Brass	Gold
	Description	Material	Finish

Unless otherwise specified tolerances
 0.5-5 = ± 0.2
 >5-30 = ± 0.4
 >30-120 = ± 0.6
 >120-315 = ± 1.0
 >315-1000 = ± 1.6
 Angles = $\pm 5^\circ$
 Units = mm

This document is the confidential property of Gigatronix Limited and may not be copied, reproduced or transmitted to any third party without written authorisation.



Author	PJP
Drawn by	PJP
Drawing date	21/02/2017
Checked by	DB
Checked date	21/02/2017
Scale	3.5: 1

Part Number MA02-0174-C01-8
Title: SMA Crimp Bulkhead Jack, Gold Plated, 8mm Hex Flange, RG174, LBC100, RG316