

**Revisions**

Issue	Date	Note
2	11/08/2021	See GTXPDC/306 - checked DB 19/10/2021

**DATASHEET**

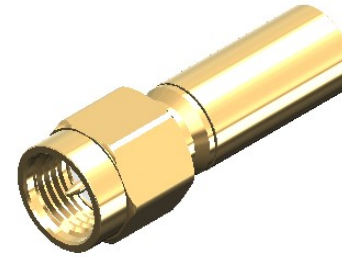

**1. Mechanical**

Cable Retention	Equal to breaking strain of cable
Durability	500 mating cycles
Mating Torque	0.79 to 1.13Nm (7-10 in-lbs)

**2. Environmental**

RoHS Compliant	Yes
Temperature Range	-65 to +165 degrees C

**3. Electrical**

Dielectric Withstanding	1000 Volts RMS Maximum
Impedance	50 ohms
Interface Frequency	12.4 GHz
Working Voltage	500 Volts RMS Maximum

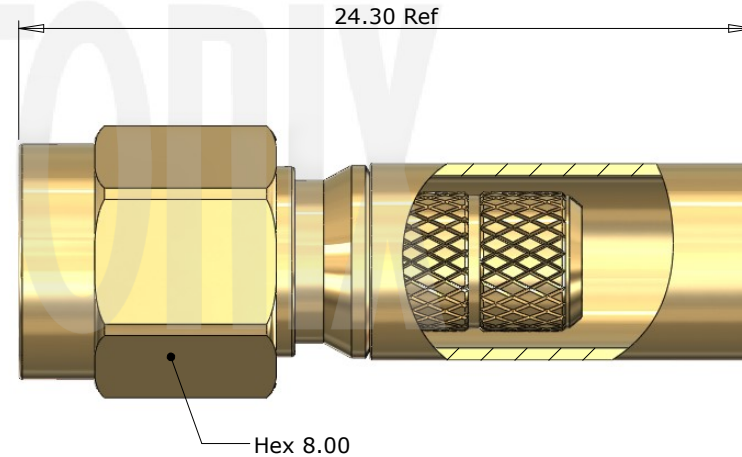

Description	Material	Finish
5 Ferrule	Brass	Gold
4 Dielectric	PTFE	White
3 Pin	Brass	Gold
2 Coupling Nut	Brass	Gold
1 Body	Brass	Gold

Unless otherwise specified tolerances  
 0.5-5 = ±0.2  
 >5-30 = ±0.4  
 >30-120 = ±0.6  
 >120-315 = ±1.0  
 >315-1000 = ±1.6  
 Angles = ±5°  
 Units = mm

This document is the confidential property of Gigatronix Limited and may not be copied, reproduced or transmitted to any third party without written authorisation.



<b>Author</b>	PJP
<b>Drawn by</b>	PJP
<b>Drawing date</b>	16/10/2015
<b>Checked by</b>	DB
<b>Checked date</b>	04/05/2017
<b>Scale</b>	Not to scale

**Part Number** MA15-0400-C01  
**Title:** SMA Crimp Plug, Gold Plated, RG142, RG223, RG400

**Revisions**

Issue	Date	Note
2	11/08/2021	See GTXPDC/306 - checked DB 19/10/2021

**ASSEMBLY INSTRUCTIONS**

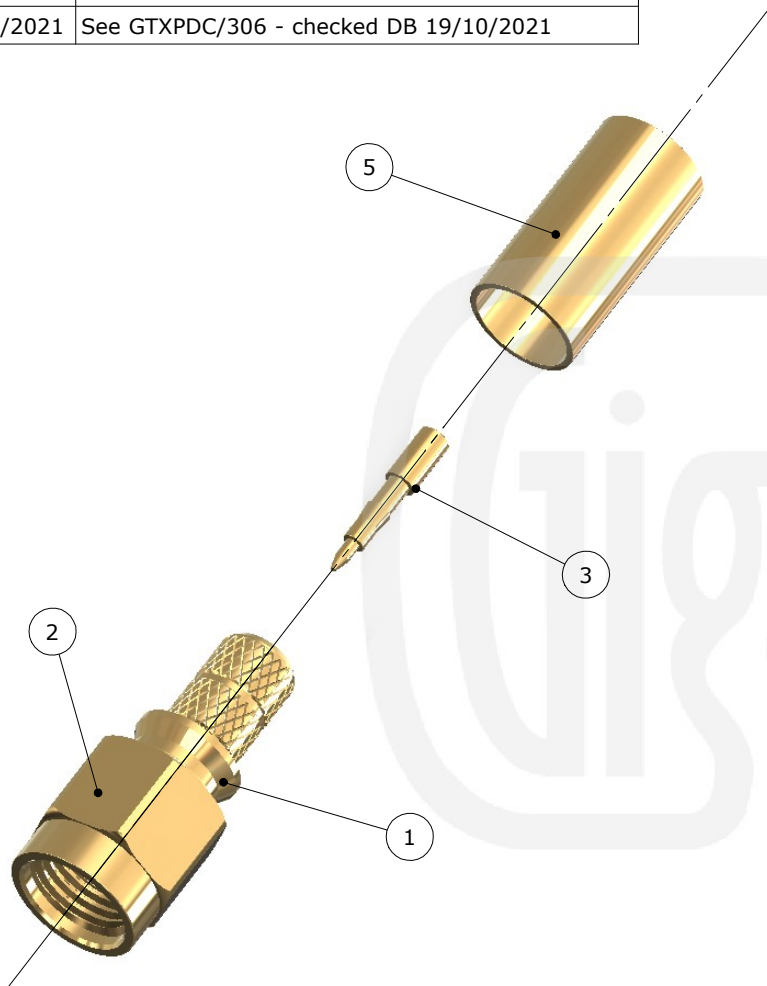

**Assembly Instructions**

1) Slide the ferrule onto the cable and strip the cable to the dimensions as shown, taking care not to nick the centre conductor or braid



2) Solder the pin onto the centre core and slide the pin into the body, ensuring that the cable braid is on the outside of the connector mandril and that the pin is located in accordance with MIL-C-39012 interface dimensional requirements.

3) Slide the ferrule forward and crimp



**Crimp Hex. Sizes:**  
5.41mm Hex, Solder centre core

**Strip Dimensions:**  
A=9.0mm, B=1.0mm, C=2.5mm



A | B | C

Description	Material	Finish
5 Ferrule	Brass	Gold
4 Dielectric	PTFE	White
3 Pin	Brass	Gold
2 Coupling Nut	Brass	Gold
1 Body	Brass	Gold

Unless otherwise specified tolerances  
 0.5-5 = ±0.2  
 >5-30 = ±0.4  
 >30-120 = ±0.6  
 >120-315 = ±1.0  
 >315-1000 = ±1.6  
 Angles = ±5°  
 Units = mm

This document is the confidential property of Gigatronix Limited and may not be copied, reproduced or transmitted to any third party without written authorisation.



<b>Author</b>	PJP
<b>Drawn by</b>	PJP
<b>Drawing date</b>	16/10/2015
<b>Checked by</b>	DB
<b>Checked date</b>	04/05/2017
<b>Scale</b>	Not to scale

<b>Part Number</b>	MA15-0400-C01
<b>Title:</b>	SMA Crimp Plug, Gold Plated, RG142, RG223, RG400