

**Revisions**

Issue	Date	Note
1	05/05/2020	See note GTXPCD/155

**ASSEMBLY VIEW**

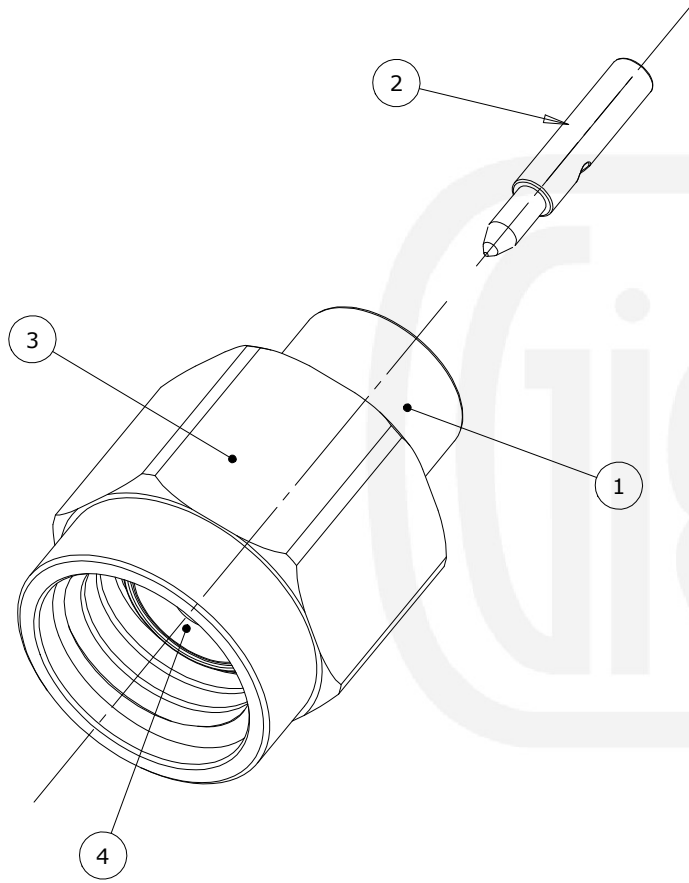

**Assembly Instructions:**

1) Strip the cable to the dimensions as shown, taking care not to nick the centre core.

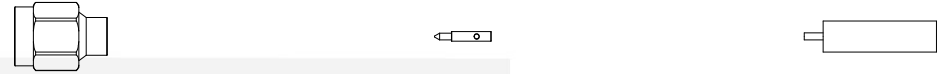

2) Solder the pin onto the centre core and slide the pin into the body, ensuring that the pin is located in accordance with MIL-C-39012 interface dimensional requirements.

3) Solder the outer shield of the cable to the connector mandril.

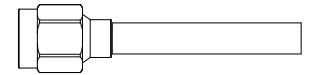

**Strip Dimensions:**

A=1.0mm, B=3.0mm

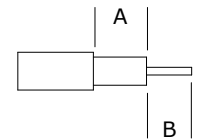

Description	Material	Finish
4 Insulator	PTFE	White
3 Coupling Nut	Brass	Gold
2 Pin	Brass	Gold
1 Body	Brass	Gold

Unless otherwise specified tolerances  
 0.5-5 = ±0.2  
 >5-30 = ±0.4  
 >30-120 = ±0.6  
 >120-315 = ±1.0  
 >315-1000 = ±1.6  
 Angles = ±5°  
 Units = mm

This document is the confidential property of Gigatronix Limited and may not be copied, reproduced or transmitted to any third party without written authorisation.



<b>Author</b>	PJP
<b>Drawn by</b>	PJP
<b>Drawing date</b>	05/05/2020
<b>Checked by</b>	DB
<b>Checked date</b>	05/05/2020
<b>Scale</b>	Not to scale

**Part Number** MA15-0402-R01

**Title:** SMA Solder Plug, Gold Plated, RG402, .141 semi-rigid