

Revisions		
Issue	Date	Note
1	27/03/2017	See note 368199368

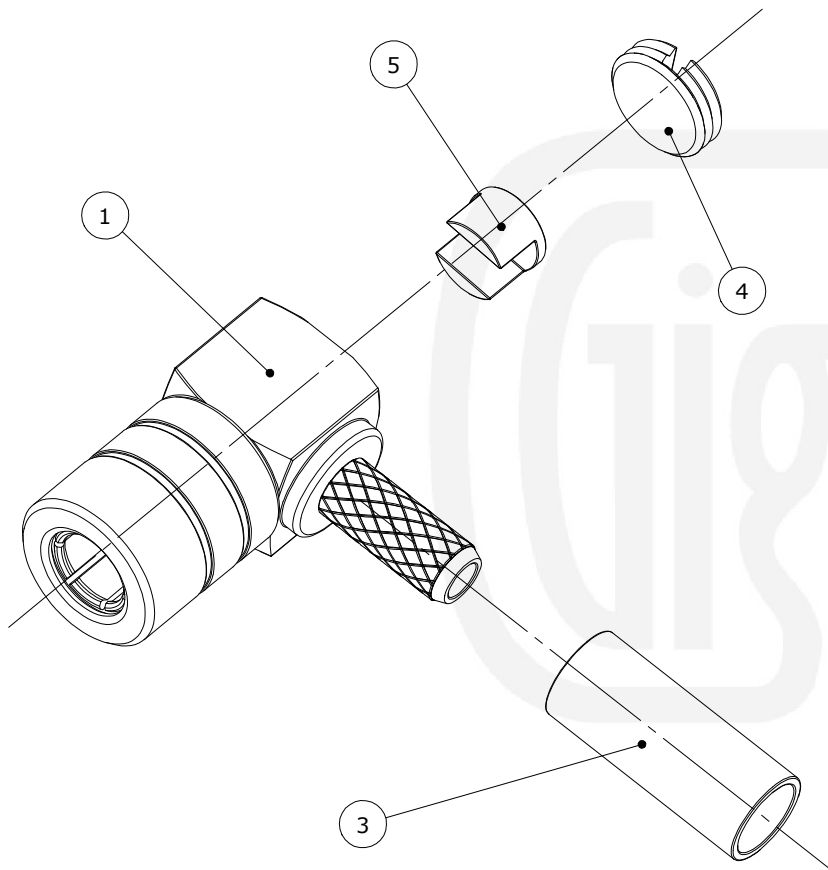

Assembly Instructions

1) Slide the ferrule onto the cable and strip the cable to the dimensions as shown, taking care not to nick the centre conductor or braid.

2) Insert the cable into the body, ensuring that the cable braid is on the outside of the connector mandril and that the centre core locates in the internal mounting post.

3) Slide the ferrule forward and crimp. Solder the centre core of the cable to the mounting post and fit the insulator and end cap.

ASSEMBLY VIEW

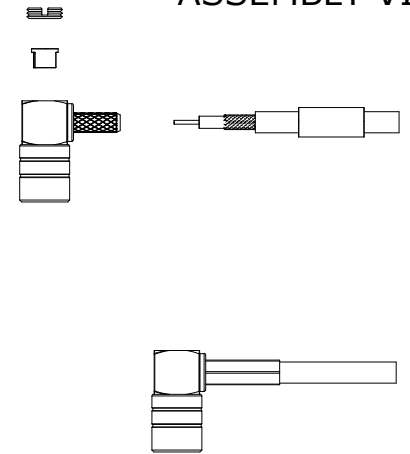

Crimp Hex. Sizes:

3.25mm Hex, Solder centre core

Strip Dimensions:

A=6.0mm, B=3.5mm, C=1.5mm

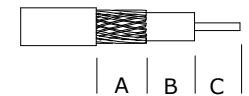

Description	Material	Finish
6 Dielectric	PTFE	White
5 Insulator	ABS	White
4 End Cap	Brass	Gold
3 Ferrule	Brass	Gold
2 Contact	Beryllium Copper	Gold
1 Body	Brass	Gold

Unless otherwise specified tolerances
0.5-5 = ±0.2
>5-30 = ±0.4
>30-120 = ±0.6
>120-315 = ±1.0
>315-1000 = ±1.6
Angles = ±5°
Units = mm

This document is the confidential property of Gigatronix Limited and may not be copied, reproduced or transmitted to any third party without written authorisation.



Author	PJP
Drawn by	PJP
Drawing date	27/03/2017
Checked by	TM
Checked date	29/03/2017
Scale	Not to scale

Part Number MB17-0174-C01

Title: SMB Crimp Right Angle Plug, Gold Plated, RG174, LBC100, RG316