

**Revisions**

Issue	Date	Note
2	01/11/2021	See GTXPDC/339 - Checked DB 01/11/2021

**DATASHEET**



**1. Mechanical**

Cable Retention Equal to breaking strain of cable  
 Durability 500 mating cycles

**2. Environmental**

RoHS Compliant Yes  
 Temperature Range -55 to +85 degrees C

**3. Electrical**

Dielectric Withstanding 1500 Volts RMS Maximum  
 Impedance 50 ohms  
 Interface Frequency 11 GHz  
 Working Voltage 500 Volts RMS Maximum

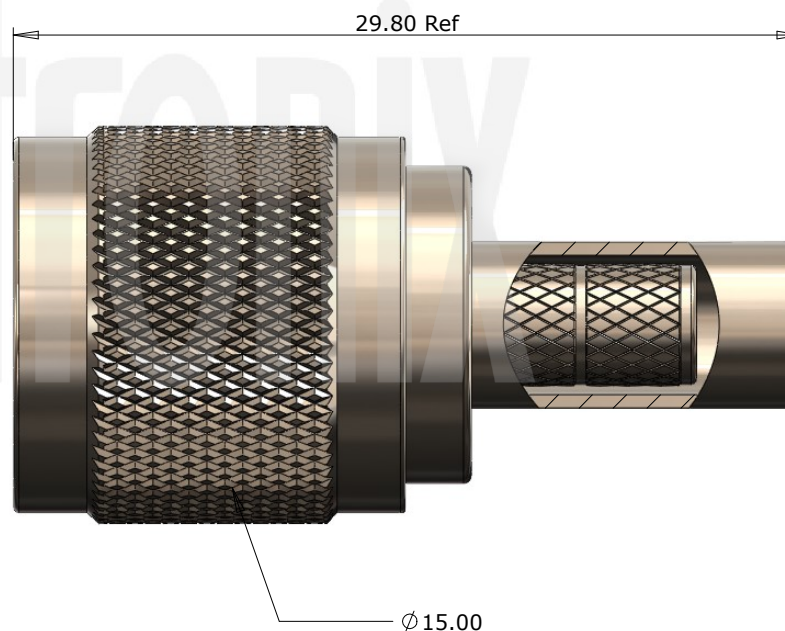

5	Dielectric	Delrin	White
4	Pin	Brass	Gold
3	Ferrule	Brass	Nickel
2	Coupling Nut	Brass	Nickel
1	Body	Brass	Nickel
	<b>Description</b>	<b>Material</b>	<b>Finish</b>

Unless otherwise specified tolerances  
 0.5-5 = ±0.2  
 >5-30 = ±0.4  
 >30-120 = ±0.6  
 >120-315 = ±1.0  
 >315-1000 = ±1.6  
 Angles = ±5°  
 Units = mm

This document is the confidential property of Gigatronix Limited and may not be copied, reproduced or transmitted to any third party without written authorisation.



<b>Author</b>	PJP
<b>Drawn by</b>	PJP
<b>Drawing date</b>	19/05/2017
<b>Checked by</b>	DB
<b>Checked date</b>	22/05/2017
<b>Scale</b>	Not to scale

**Part Number** TN15-0058-C06  
**Title:** TNC Crimp Plug, Nickel Plated, RG58, LBC195, URM43

**Revisions**

Issue	Date	Note
2	01/11/2021	See GTXPDC/339 - Checked DB 01/11/2021

**ASSEMBLY INSTRUCTIONS**

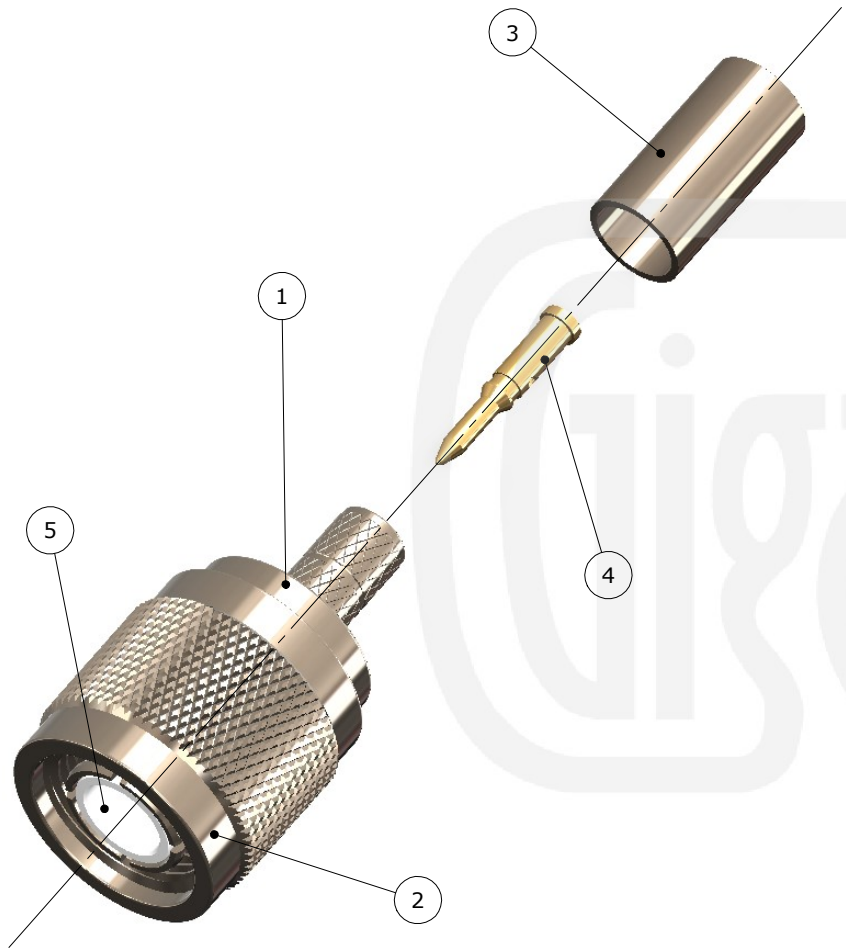

**Assembly Instructions:**

1) Slide the ferrule onto the cable and strip the cable to the dimensions as shown, taking care not to nick the centre conductor or braid



2) Crimp the pin onto the centre core and slide the pin into the body until it captivates, ensuring that the cable braid is on the outside of the connector mandril

3) Slide the ferrule forward and crimp



**Crimp Hex. Sizes:**

5.41mm Hex, 1.69mm Hex

**Strip Dimensions:**

A=8.5mm, B=4.5mm, C=4.0mm



Description	Material	Finish
5 Dielectric	Delrin	White
4 Pin	Brass	Gold
3 Ferrule	Brass	Nickel
2 Coupling Nut	Brass	Nickel
1 Body	Brass	Nickel

Unless otherwise specified tolerances  
 0.5-5 = ±0.2  
 >5-30 = ±0.4  
 >30-120 = ±0.6  
 >120-315 = ±1.0  
 >315-1000 = ±1.6  
 Angles = ±5°  
 Units = mm

This document is the confidential property of Gigatronix Limited and may not be copied, reproduced or transmitted to any third party without written authorisation.



<b>Author</b>	PJP
<b>Drawn by</b>	PJP
<b>Drawing date</b>	19/05/2017
<b>Checked by</b>	DB
<b>Checked date</b>	22/05/2017
<b>Scale</b>	Not to scale

<b>Part Number</b>	TN15-0058-C06
<b>Title:</b>	TNC Crimp Plug, Nickel Plated, RG58, LBC195, URM43